



CP20.241, CP20.241-C1, CP20.241-S1, CP20.241-S2, CP20.241-V1, CP20.242

DIMENSION CP-Series

24V, 20A, 480W, SINGLE PHASE



POWER SUPPLY

- AC 100-240V Wide-range Input
- Width only 48mm
- Efficiency up to 95.6%
- Excellent Partial Load Efficiency
- 20% Output Power Reserves
- Easy Fuse Breaking – 3 times nominal current for 12ms
- Safe Hiccup^{PLUS} Overload Mode
- Active Power Factor Correction (PFC)
- Minimal Inrush Current Surge
- Full Power Between -25°C and +60°C
- DC-OK Relay Contact
- Current Sharing Feature for Parallel Use
- 3 Year Warranty

GENERAL DESCRIPTION

The Dimension CP-Series are cost optimized power supplies without compromising quality, reliability and performance. The most outstanding features of the CP20 series are the high efficiency, electronic inrush current limitation, active PFC, wide operational temperature range and the extraordinary small size.

The CP20.241-C1 is equipped with conformal coated pc-boards preferred for applications in harsh areas.

The CP20.241-S1 is equipped with quick-connect spring-clamp terminals preferred for applications which are exposed to mechanical vibration. The CP20.241-S2 has push-in terminals optimized for easy cabinet wiring.

The CP20.241-V1 is equipped with a remote ON/OFF feature and the CP20.242 features an enhanced DC input voltage range.

The devices have a power reserve of 20% included, which may even be used continuously up to +45°C.

High immunity to transients and power surges as well as low electromagnetic emission, a DC-OK relay contact and a large international approval package makes this unit suitable for nearly every situation.

SHORT-FORM DATA

Output voltage	DC 24V	Nominal
Adjustment range	24 - 28V	Factory setting 24.1V
Output current	24.0 - 20.6A	Below +45°C ambient
	20.0 - 17.1A	At +60°C ambient
	15.0 - 13.0A	At +70°C ambient
	Derate linearly between +45°C and +70°C	
Input voltage AC	AC 100-240V	-15%/+10%
Mains frequency	50-60Hz	±6%
Input current AC	4.26 / 2.23A	At 120 / 230Vac
Power factor	0.99 / 0.98	At 120 / 230Vac
Input voltage DC	DC 110-150V ^{±20%}	For CP20.241 (-xx)
	DC 110-300V ^{±20%}	For CP20.242
Input current DC	4.64A / 1.66A	At 110 / 300Vdc
AC Inrush current	10.0 / 4.5A _{pk}	At 120 / 230Vac
Efficiency	94.2 / 95.6%	At 120 / 230Vac
Losses	29.6 / 22.1W	At 120 / 230Vac
Hold-up time	32/ 32ms	At 120 / 230Vac
Temperature range	-25°C to +70°C	
Size (WxHxD)	48x124x127mm	Without DIN-rail
Weight	830g / 1.83lb	

ORDER NUMBERS

Power Supply	CP20.241
	CP20.241-C1 With conformal coated pc-boards
	CP20.241-S1 With quick-connect spring-clamp terminals
	CP20.241-S2 With push-in terminals
	CP20.241-V1 With remote ON/OFF feature
	CP20.242 Enhanced DC input

Mechanical Accessory	ZM5.WALL	Wall/Panel mount bracket
----------------------	----------	--------------------------

MARKINGS

For details or a complete approval list see section 20.



INDEX

	Page		Page
1. Intended Use	3	20. Approvals	23
2. Installation Requirements	3	21. Other Fulfilled Standards	23
3. AC-Input	5	22. Physical Dimensions and Weight	24
4. DC-Input	6	23. Accessories	25
5. Input Inrush Current	7	23.1. UF20.241 Buffer Module	25
6. Output	8	23.2. YR40.241/242 - Redundancy Modules	25
7. Hold-up Time	10	23.3. YR40.245 - Redundancy Modules	25
8. DC-OK Relay Contact	11	23.4. ZM5.WALL – Wall/Panel Mount Bracket	26
9. Remote ON / OFF Function (CP20.241-V1 only)	11	24. Application Notes	27
10. Efficiency and Power Losses	12	24.1. Peak Current Capability	27
11. Lifetime Expectancy	13	24.2. Output Circuit Breakers	28
12. MTBF	13	24.3. Series Operation	29
13. Functional Diagram	14	24.4. Parallel Use to Increase Output Power	29
14. Terminals and Wiring	15	24.5. Parallel Use for Redundancy	30
15. Front Side and User Elements	17	24.6. Charging of Batteries	31
16. EMC	18	24.7. Operation on Two Phases	31
17. Environment	20	24.8. Use in a Tightly Sealed Enclosure	31
18. Safety and Protection Features	21	24.9. Mounting Orientations	32
19. Dielectric Strength	22		

The information given in this document is correct to the best of our knowledge and experience at the time of publication. If not expressly agreed otherwise, this information does not represent a warranty in the legal sense of the word. As the state of our knowledge and experience is constantly changing, the information in this data sheet is subject to revision. We therefore kindly ask you to always use the latest issue of this document (available under www.pulspower.com).

No part of this document may be reproduced or utilized in any form without our prior permission in writing.

TERMINOLOGY AND ABBREVIATIONS

PE and \oplus symbol	PE is the abbreviation for Protective Earth and has the same meaning as the symbol \oplus .
Earth, Ground	This document uses the term "earth" which is the same as the U.S. term "ground".
T.b.d.	To be defined, value or description will follow later.
AC 230V	A figure displayed with the AC or DC before the value represents a nominal voltage with standard tolerances (usually $\pm 15\%$) included. E.g.: DC 12V describes a 12V battery disregarding whether it is full (13.7V) or flat (10V)
230Vac	A figure with the unit (Vac) at the end is a momentary figure without any additional tolerances included.
50Hz vs. 60Hz	As long as not otherwise stated, AC 230V parameters are valid at 50Hz mains frequency.
may	A key word indicating flexibility of choice with no implied preference.
shall	A key word indicating a mandatory requirement.
should	A key word indicating flexibility of choice with a strongly preferred implementation.

PULSCP20.241, CP20.241-C1, CP20.241-S1,
CP20.241-S2, CP20.241-V1, CP20.242

DIMENSION CP-Series

24V, 20A, 480W, SINGLE PHASE

1. INTENDED USE

This device is designed for installation in an enclosure and is intended for the general professional use such as in industrial control, office, communication, and instrumentation equipment.

Do not use this power supply in equipment, where malfunction may cause severe personal injury or threaten human life.

2. INSTALLATION REQUIREMENTS

⚠ WARNING Risk of electrical shock, fire, personal injury or death.

- Do not use the power supply without proper grounding (Protective Earth). Use the terminal on the input block for earth connection and not one of the screws on the housing.
- Turn power off before working on the device. Protect against inadvertent re-powering.
- Make sure that the wiring is correct by following all local and national codes.
- Do not modify or repair the unit.
- Do not open the unit as high voltages are present inside.
- Use caution to prevent any foreign objects from entering the housing.
- Do not use in wet locations or in areas where moisture or condensation can be expected.
- Do not touch during power-on, and immediately after power-off. Hot surfaces may cause burns.

Obey the following installation requirements:

- This device may only be installed and put into operation by qualified personnel.
- Install the device in an enclosure providing protection against electrical, mechanical and fire hazards.
- The device is designed for use in pollution degree 2 areas in controlled environments.
- The enclosure of the device provides a degree of protection of IP20 according to IEC 60529.
- Mount the unit on a DIN-rail so that the input terminals are located on the bottom of the unit. For other mounting orientations see de-rating requirements in this document.
- The device is designed for convection cooling and does not require an external fan. Do not obstruct airflow and do not cover ventilation grid (e.g. cable conduits) by more than 15%!
- Keep the following installation clearances: 40mm on top, 20mm on the bottom, 5mm on the left and right sides are recommended when the device is loaded permanently with more than 50% of the rated power. Increase this clearance to 15mm in case the adjacent device is a heat source (Example: another power supply).
- Make sure that the wiring is correct by following all local and national codes. Use appropriate copper cables that are designed for a minimum operating temperature of 60°C for ambient temperatures up to +45°C, 75°C for ambient temperatures up to +60°C and 90°C for ambient temperatures up to +70°C. Ensure that all strands of a stranded wire enter the terminal connection. Check also local codes and local requirements. In some countries local regulations might apply.
- This device does not contain serviceable parts. The tripping of an internal fuse is caused by an internal defect. If damage or malfunction should occur during installation or operation, immediately turn power off and send the device to the factory for inspection.
- The device is designed, tested and approved for branch circuits up to up to 30A (UL) or 32A (IEC) without additional protection device. If an external fuse is utilized, do not use circuit breakers smaller than 10A B- or C-Characteristic to avoid a nuisance tripping of the circuit breaker.
- A disconnecting means shall be provided for the input of the power supply.

Notes for use in hazardous location areas:

The power supply is suitable for use in Class I Division 2 Groups A, B, C, D locations. See chapter 20 for details.

WARNING EXPLOSION HAZARDS!

Substitution of components may impair suitability for this environment. Do not disconnect the unit or operate the voltage adjustment or S/P jumper unless power has been switched off or the area is known to be non-hazardous.

Wiring must be in accordance with Class I, Division 2 wiring methods of the National Electrical Code, NFPA 70, and in accordance with other local or national codes.

A suitable enclosure must be provided for the end product which has a minimum protection of IP54 and fulfils the requirements of the EN 60079-0.

3. AC-INPUT

The device is suitable to be supplied from TN-, TT- and IT mains networks with AC voltage. For suitable DC supply voltages see chapter 4.

AC input	Nom.	AC 100-240V	
AC input range	Min.	85-264Vac	Continuous operation
	Min.	264-300Vac	For maximal 500ms (occasional)
Allowed voltage L or N to earth	Max.	300Vac	Continuous, according to IEC 62477-1
Input frequency	Nom.	50–60Hz	±6%
Turn-on voltage	Typ.	82Vac	Steady-state value, see Fig. 3-1
Shut-down voltage	Typ.	72Vac	Steady-state value, see Fig. 3-1
External input protection	See recommendations in chapter 2.		

		AC 100V	AC 120V	AC 230V	
Input current	Typ.	5.15A	4.26A	2.23A	At 24V, 20A, see Fig. 3-3
Power factor	Typ.	0.996	0.996	0.980	At 24V, 20A, see Fig. 3-4
Crest factor ^{*)}	Typ.	1.65	1.63	1.63	At 24V, 20A, The crest factor is the mathematical ratio of the peak value to RMS value of the input current waveform.
Start-up delay	Typ.	450ms	420ms	440ms	See Fig. 3-2
Rise time	Typ.	145ms	145ms	145ms	At 24V, 20A const. current load, 0mF load capacitance, see Fig. 3-2
	Typ.	160ms	160ms	160ms	At 24V, 20A const. current load, 20mF load capacitance, see Fig. 3-2
Turn-on overshoot	Max.	200mV	200mV	200mV	In single use mode, see Fig. 3-2

Fig. 3-1 **Input voltage range**

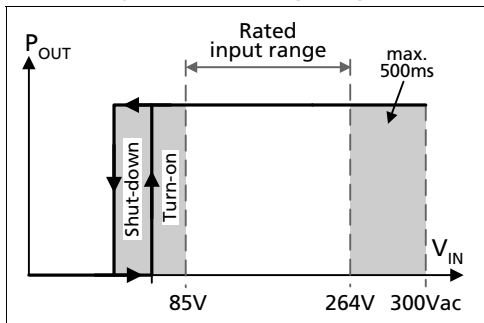

Fig. 3-3 **Input current vs. output current at 24V output voltage**

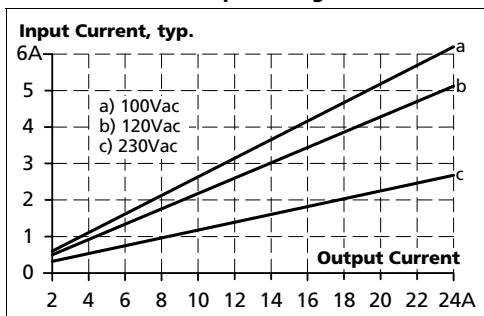

Fig. 3-2 **Turn-on behavior, definitions**

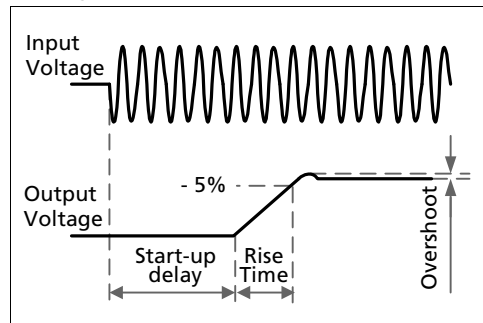
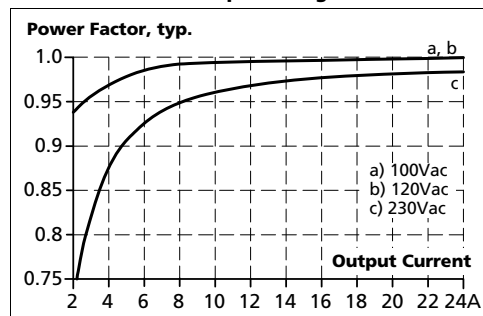

Fig. 3-4 **Power factor vs. output current at 24V output voltage**



Jan. 2018 / Rev. 0.5 DS-CP20.241-EN - All parameters are typical values specified at 230Vac, 50Hz input voltage, 24V, 20A output load, 25°C ambient and after a 5 minutes run-in time unless otherwise noted.

4. DC-INPUT

The device is suitable to be supplied from a DC input voltage. Use a battery or a similar DC source. A supply from the intermediate DC-bus of a frequency converter is not recommended and can cause a malfunction or damage the unit. Connect +pole to L, -pole to N and the PE terminal to an earth wire or to the machine ground.

DC input	Nom.	DC 110-150V	±20% For CP20.241, CP20.241-C1, CP20.241-S1, CP20.241-S2, CP20.241-V1
	Nom.	DC 110-300V	±20% For CP20.242
DC input range	Min.	88-180Vdc	Continuous operation for CP20.241, CP20.241-C1, CP20.241-S1, CP20.241-S2, CP20.241-V1
		88-360Vdc	Continuous operation for CP20.242
DC input current	Typ.	4.64A	At 110Vdc, at 24V, 20A
	Typ.	1.66A	At 300Vdc, at 24V, 20A
Allowed Voltage (+) or (-) input to Earth	Max.	375Vdc	Continuous according to IEC 62477-1
Turn-on voltage	Typ.	80Vdc	Steady state value
Shut-down voltage	Typ.	70Vdc	Steady state value

Fig. 4-1 **Wiring for DC Input**

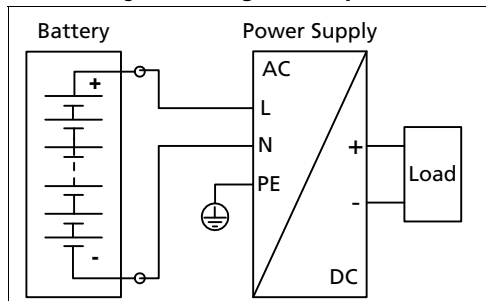

5. INPUT INRUSH CURRENT

An active inrush limitation circuit limits the input inrush current after turn-on of the input voltage. The charging current into EMI suppression capacitors is disregarded in the first microseconds after switch-on.

		AC 100V	AC 120V	AC 230V	
Inrush current	Max.	15A _{peak}	12A _{peak}	5.5A _{peak}	Temperature independent
	Typ.	12A _{peak}	10A _{peak}	4.5A _{peak}	Temperature independent
Inrush energy	Max.	1A ² s	1A ² s	1A ² s	Temperature independent

Fig. 5-1 Typical turn-on behavior at nominal load and 25°C ambient

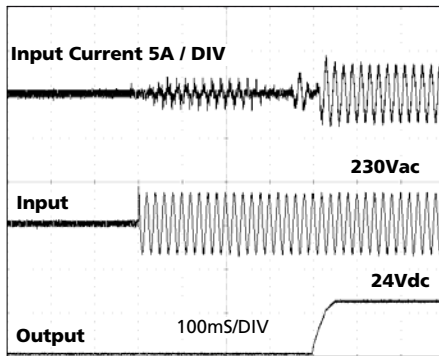

6. OUTPUT

The output provides a SELV/PELV rated voltage, which is galvanically isolated from the input voltage.

The output is designed to supply any kind of loads, including capacitive and inductive loads. If extreme large capacitors, such as EDLCs (electric double layer capacitors or "UltraCaps") with a capacitance > 1F are connected to the output, the unit might charge the capacitor in the Hiccup^{PLUS} mode.

Output voltage	Nom.	24V	
Adjustment range	Min.	24-28V	Guaranteed value
	Max.	30V	This is the maximum output voltage which can occur at the clockwise end position of the potentiometer due to tolerances. It is not a guaranteed value which can be achieved.
Factory setting output voltage	Typ.	24.1V	In "single use" mode: ±0.2%, at full load, cold unit In "parallel use" mode: ±0.2%, at 20A, cold unit (results to 23.9V±0.2% at 24A and 25.1V±0.2% at no load)
Line regulation	Max.	10mV	Between 85 and 300Vac input voltage change
Load regulation	Max.	100mV	Between 0 and 24A in "single use" mode, static value
	Typ.	1000mV	Between 0 and 24A in "parallel use" mode, static value, see Fig. 6-2
Ripple and noise voltage	Max.	50mVpp	Bandwidth 20Hz to 20MHz, 50Ohm
Output current	Nom.	24A ¹⁾	At 24V and an ambient temperature below 45°C
	Nom.	20A	At 24V and 60°C ambient temperature
	Nom.	15A	At 24V and 70°C ambient temperature
	Nom.	20.6A ¹⁾	At 28V and an ambient temperature below 45°C
	Nom.	17.1A	At 28V and 60°C ambient temperature
	Nom.	13A	At 28V and 70°C ambient temperature
			Derate linearly between +45°C and +70°C
Fuse breaking current	Typ.	60A	Up to 12ms once every five seconds, see Fig. 6-4. The fuse braking current is an enhanced transient current which helps to start heavy loads or to trip fuses on faulty output branches. The output voltage stays above 20V. See chapter 24.1 for additional measurements.
Overload protection	Included		Electronically protected against overload, no-load and short-circuits. In case of a protection event, audible noise may occur.
Overload behavior	Continuous current		Output voltage above 13Vdc, see Fig. 6-1
	Intermitted current ²⁾		Output voltage below 13Vdc, see Fig. 6-1
Overload/ short-circuit current	Min.	26A	Continuous current, see Fig. 6-1
	Max.	29.8A	Continuous current, see Fig. 6-1
	Typ.	29A	Intermitted current peak value for typ. 2s Load impedance 10mOhm, see Fig. 6-3 Discharge current of output capacitors is not included.
	Max.	9.8A	Intermitted current average value (R.M.S.) Load impedance 10mOhm, see Fig. 6-3
Output capacitance	Typ.	8 500µF	Included inside the power supply

Back-feeding loads	Max. 35V	The unit is resistant and does not show malfunctioning when a load feeds back voltage to the power supply. It does not matter whether the power supply is on or off. The absorbing energy can be calculated according to the built-in large sized output capacitor.
--------------------	----------	---

- 1) This current is also available for temperatures up to +70°C with a duty cycle of 10% and/or not longer than 1 minute every 10 minutes.
- 2) Hiccup^{PLUS} Mode
 At heavy overloads (when output voltage falls below 13V), the power supply delivers continuous output current for 2s. After this, the output is switched off for approx. 18s before a new start attempt is automatically performed. This cycle is repeated as long as the overload exists. If the overload has been cleared, the device will operate normally. See Fig. 6-3.

Fig. 6-1 Output voltage vs. output current, typ.

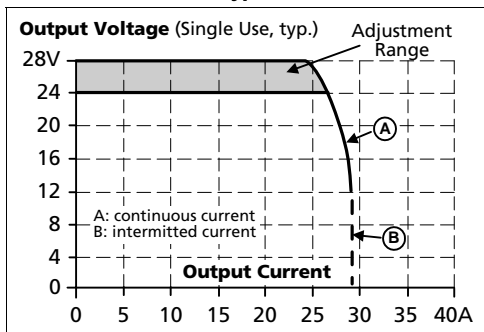

Fig. 6-2 Output voltage in "parallel use" mode, typ.

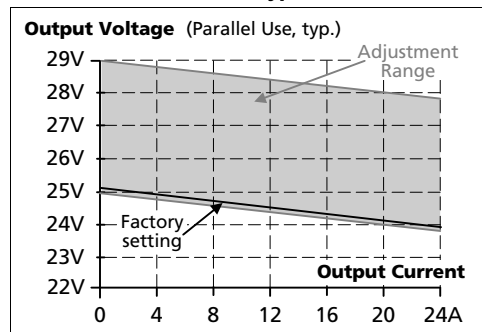

Fig. 6-3 Short-circuit on output, Hiccup^{PLUS} mode, typ.

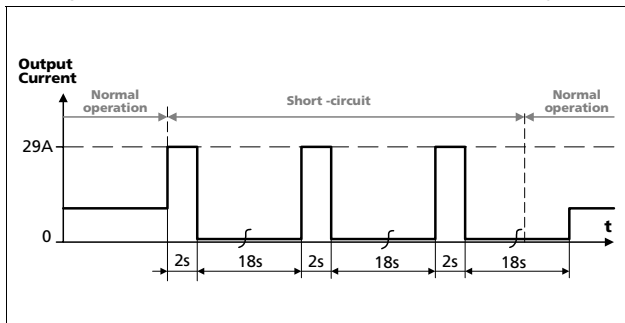
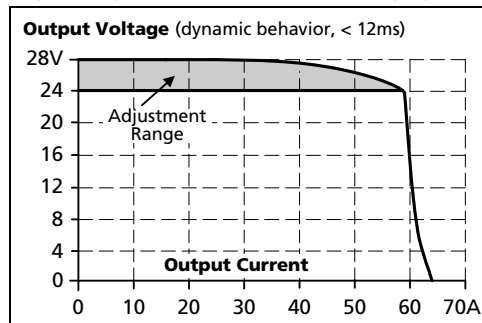

Fig. 6-4 Dynamic overcurrent capability, typ.



7. HOLD-UP TIME

		AC 100V	AC 120V	AC 230V	
Hold-up Time	Typ.	65ms	65ms	65ms	At 24V, 10A, see Fig. 7-1
	Min.	54ms	54ms	54ms	At 24V, 10A, see Fig. 7-1
	Typ.	32ms	32ms	32ms	At 24V, 20A, see Fig. 7-1
	Min.	24ms	24ms	24ms	At 24V, 20A, see Fig. 7-1

Fig. 7-1 Hold-up time vs. input voltage

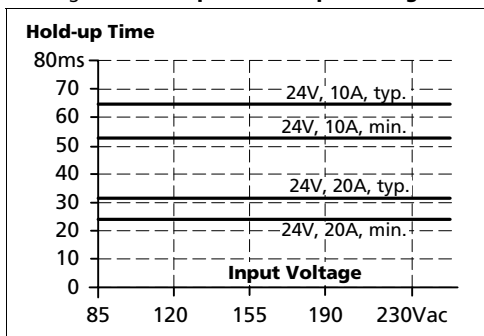
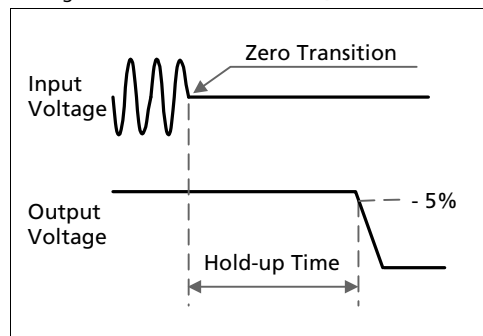

Fig. 7-2 Shut-down behavior, definitions



8. DC-OK RELAY CONTACT

This feature monitors the output voltage on the output terminals of a running power supply.

Contact closes	As soon as the output voltage reaches typ. 90% of the adjusted output voltage level.
Contact opens	As soon as the output voltage dips more than 10% below the adjusted output voltage. Short dips will be extended to a signal length of 100ms. Dips shorter than 1ms will be ignored.
Switching hysteresis	1V
Contact ratings	Maximal 60Vdc 0.3A, 30Vdc 1A, 30Vac 0.5A, resistive load Minimal permissible load: 1mA at 5Vdc
Isolation voltage	See dielectric strength table in section 18.

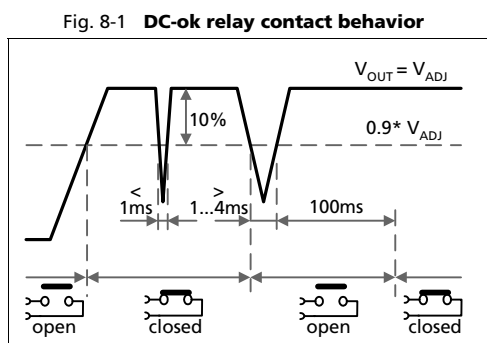

9. REMOTE ON / OFF FUNCTION (CP20.241-V1 ONLY)

This feature allows to switch-off the power supply output with a signal switch or transistor. A link between pin 15 and 16 turns the power supply on. Pin 15 is referenced to the (-) output voltage. The open-loop voltage between pin 16 and pin 15 can be up to 18V. The maximum current, when in remote ON mode, can be up to 2.5mA.

The threshold level to switch-off the output is typically 5V and the turn-on threshold is typically 9V.

When multiple power supplies are connected in parallel, pin 15 and pin 16 are also allowed to be paralleled to control all units with the same switch or transistor.

Please note: The remote ON/OFF function has no safety feature included.

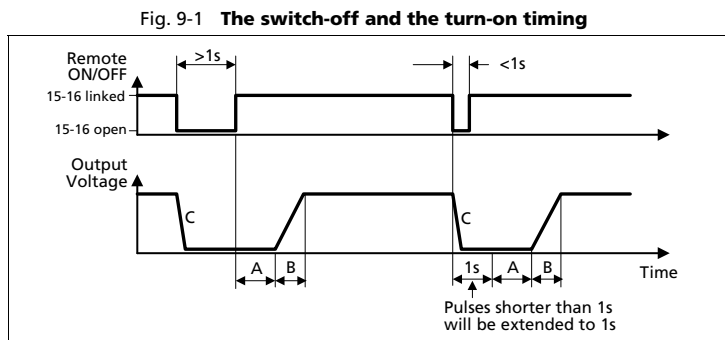
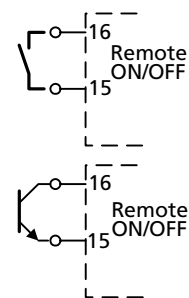

- A:** Turn-on delay acc. Fig. 3-2
- B:** Rise time acc. Fig. 3-2
- C:** No active discharge of the output after switch-off

10. EFFICIENCY AND POWER LOSSES

		AC 100V	AC 120V	AC 230V	
Efficiency	Typ.	93.6%	94.2%	95.6%	At 24V, 20A
	Typ.	93.5%	94.1%	95.5%	At 24V, 24A (Power Boost)
Average efficiency ^{*)}	Typ.	93.2%	93.8%	95.0%	25% at 5A, 25% at 10A, 25% at 15A. 25% at 20A
Power losses	typ.	T.B.D.	T.B.D.	T.B.D.	CP20.241-V1 in "Remote OFF" mode
	Typ.	2.5W	2.2W	2.2W	At 24V, 0A
	Typ.	16.0W	15.0W	12.5W	At 24V, 10A
	Typ.	32.8W	29.6W	22.1W	At 24V, 20A
	Typ.	40.0W	36.1W	27.1W	At 24V, 24A (Power Boost)

*) The average efficiency is an assumption for a typical application where the power supply is loaded with 25% of the nominal load for 25% of the time, 50% of the nominal load for another 25% of the time, 75% of the nominal load for another 25% of the time and with 100% of the nominal load for the rest of the time.

Fig. 10-1 **Efficiency vs. output current at 24V, typ**

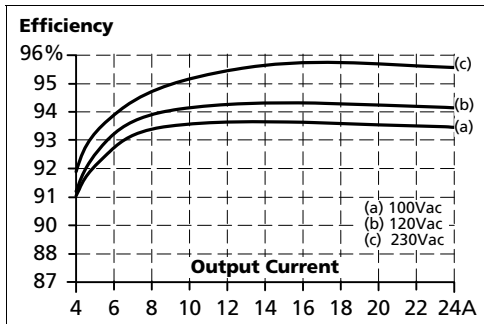

Fig. 10-2 **Losses vs. output current at 24V, typ.**

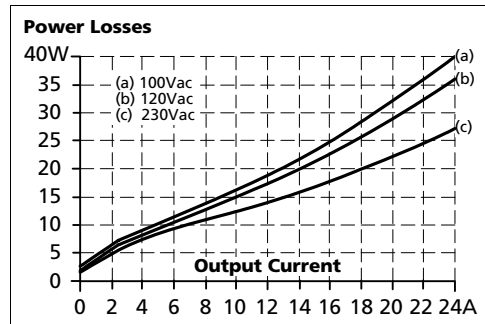

Fig. 10-3 **Efficiency vs. input voltage at 24V, 20A, typ.**

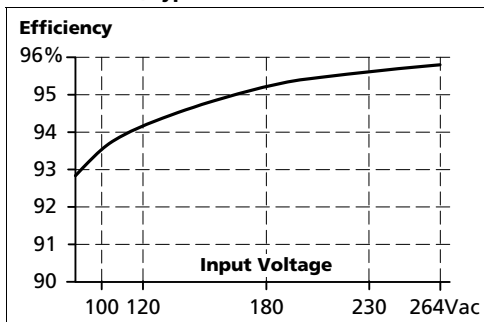
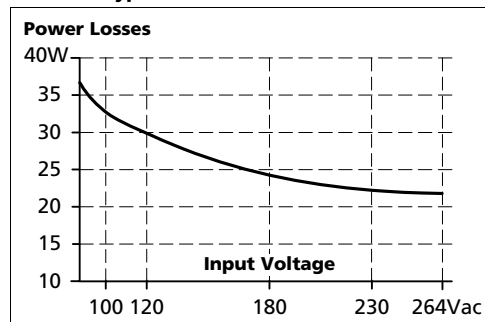

Fig. 10-4 **Losses vs. input voltage at 24V, 20A, typ.**



11. LIFETIME EXPECTANCY

The Lifetime expectancy shown in the table indicates the minimum operating hours (service life) and is determined by the lifetime expectancy of the built-in electrolytic capacitors. Lifetime expectancy is specified in operational hours and is calculated according to the capacitor's manufacturer specification. The manufacturer of the electrolytic capacitors only guarantees a maximum life of up to 15 years (131 400h). Any number exceeding this value is a calculated theoretical lifetime which can be used to compare devices.

	AC 100V	AC 120V	AC 230V	
Lifetime expectancy	123 000h	149 000h	173 000h	At 24V, 10A and 40°C
	348 000h	422 000h	488 000h	At 24V, 10A and 25°C
	48 000h	60 000h	94 000h	At 24V, 20A and 40°C
	136 000h	169 000h	265 000h	At 24V, 20A and 25°C
	23 000h	31 000h	54 000h	At 24V, 24A and 40°C
	64 000h	88 000h	152 000h	At 24V, 24A and 25°C

12. MTBF

MTBF stands for **Mean Time Between Failure**, which is calculated according to statistical device failures, and indicates reliability of a device. It is the statistical representation of the likelihood of a unit to fail and does not necessarily represent the life of a product.

The MTBF figure is a statistical representation of the likelihood of a device to fail. A MTBF figure of e.g. 1 000 000h means that statistically one unit will fail every 100 hours if 10 000 units are installed in the field. However, it can not be determined if the failed unit has been running for 50 000h or only for 100h.

For these types of units the MTTF (**Mean Time To Failure**) value is the same value as the MTBF value.

	AC 100V	AC 120V	AC 230V	
MTBF SN 29500, IEC 61709	422 000h	445 000h	590 000h	At 24V, 20A and 40°C
	790 000h	832 000h	1 060 000h	At 24V, 20A and 25°C
MTBF MIL HDBK 217F	186 000h	191 000h	226 000h	At 24V, 20A and 40°C; Ground Benign GB40
	256 000h	263 000h	313 000h	At 24V, 20A and 25°C; Ground Benign GB25
	40 000h	42 000h	50 000h	At 24V, 20A and 40°C; Ground Fixed GF40
	53 000h	55 000h	67 000h	At 24V, 20A and 25°C; Ground Fixed GF25

13. FUNCTIONAL DIAGRAM

Fig. 13-1 **Functional diagram CP20.241, CP20.241-C1, CP20.241-S1, CP20.242**

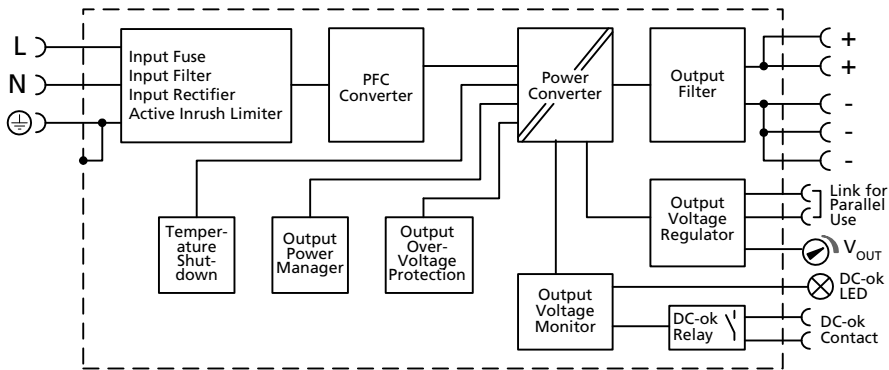

Fig. 13-2 **Functional diagram CP20.241-S2**

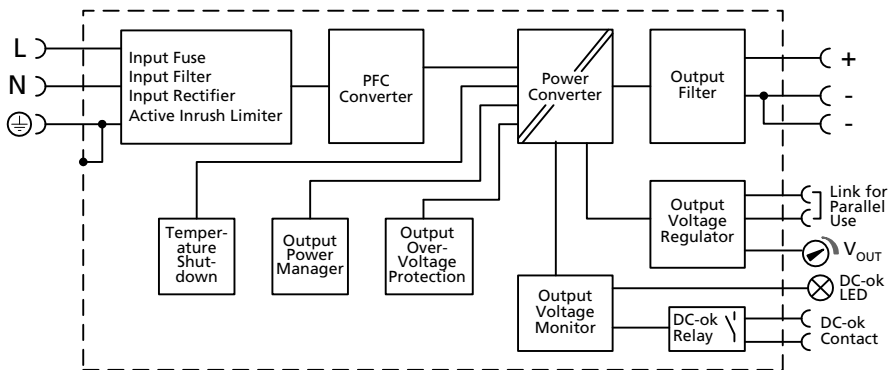
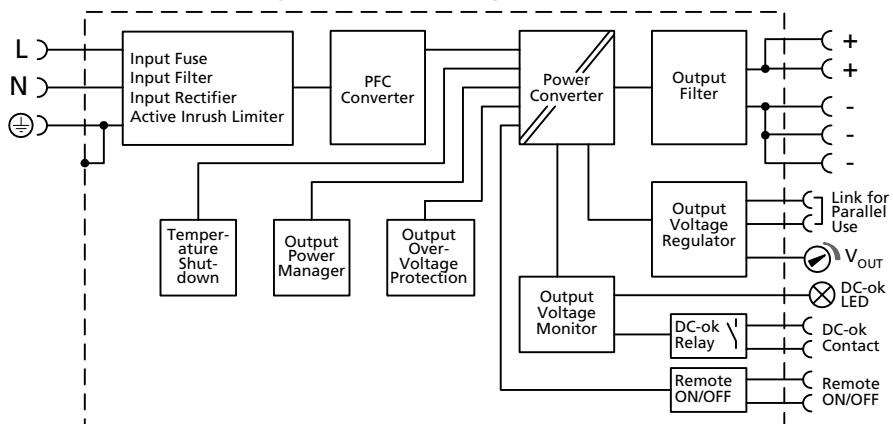

Fig. 13-3 **Functional diagram CP20.241-V1**



14. TERMINALS AND WIRING

The terminals are IP20 Finger safe constructed and suitable for field- and factory wiring.

CP20.241, CP20.241-C1, CP20.241-V1, CP20.242	Input	Output	Signal Terminals
Type	Screw termination	Screw termination	Push-in termination
Solid wire	Max. 6mm ²	Max. 6mm ²	Max. 1.5mm ²
Stranded wire	Max. 4mm ²	Max. 4mm ²	Max. 1.5mm ²
American Wire Gauge	AWG 20-10	AWG 20-10	AWG 24-16
Max. wire diameter (including ferrules)	2.8mm	2.8mm	1.6mm
Recommended tightening torque	Max. 1Nm, 9lb-in	Max. 1Nm, 9lb-in	-
Wire stripping length	7mm / 0.28inch	7mm / 0.28inch	7mm / 0.28inch
Screwdriver	3.5mm slotted or cross-head No 2	3.5mm slotted or cross-head No 2	3mm slotted to open the spring

CP20.241-S1	Input	Output	Signal Terminals
Type	Quick-connect spring-clamp termination	Quick-connect spring-clamp termination	Push-in termination
Solid wire	Max. 6mm ²	Max. 6mm ²	Max. 1.5mm ²
Stranded wire	Max. 4mm ²	Max. 4mm ²	Max. 1.5mm ²
American Wire Gauge	AWG 20-10	AWG 20-10	AWG 24-16
Max. wire diameter (including ferrules)	2.8mm	2.8mm	1.6mm
Wire stripping length	10mm / 0.4inch	10mm / 0.4inch	7mm / 0.28inch
Screwdriver	-	-	3mm slotted to open the spring

CP20.241-S2	Input	Output	Signal Terminals
Type	Push-in termination	Push-in termination	Push-in termination
Solid wire	Max. 2.5mm ²	Max. 10mm ²	Max. 1.5mm ²
Stranded wire	Max. 2.5mm ²	Max. 6mm ²	Max. 1.5mm ²
Stranded wire with ferrules	Max. 1.5mm ²	Max. 4mm ²	Max. 1.5mm ²
American Wire Gauge	AWG 24-12	AWG 24-8	AWG 24-16
Max. wire diameter (including ferrules)	2.3mm	3.3mm	1.6mm
Wire stripping length	10mm / 0.4inch	15mm / 0.6inch	7mm / 0.28inch
Screwdriver	3.0mm slotted to open the spring	3.5mm slotted to open the spring	3mm slotted to open the spring

Instructions for wiring:

- a) Use appropriate copper cables that are designed for minimum operating temperatures of:
 - 60°C for ambient up to 45°C and
 - 75°C for ambient up to 60°C and
 - 90°C for ambient up to 70°C minimum.
- b) Follow national installation codes and installation regulations!
- c) Ensure that all strands of a stranded wire enter the terminal connection!
- d) Unused terminal compartments should be securely tightened.

Daisy chaining:

Daisy chaining (jumping from one power supply output to the next) is not allowed. Use a separate distribution terminal block as shown in Fig. 14-1.

Fig. 14-1 Using distribution terminals

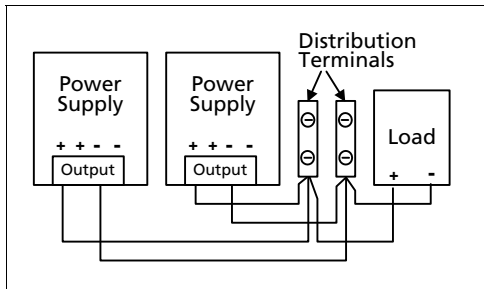

15. FRONT SIDE AND USER ELEMENTS

Fig. 15-1 Front side

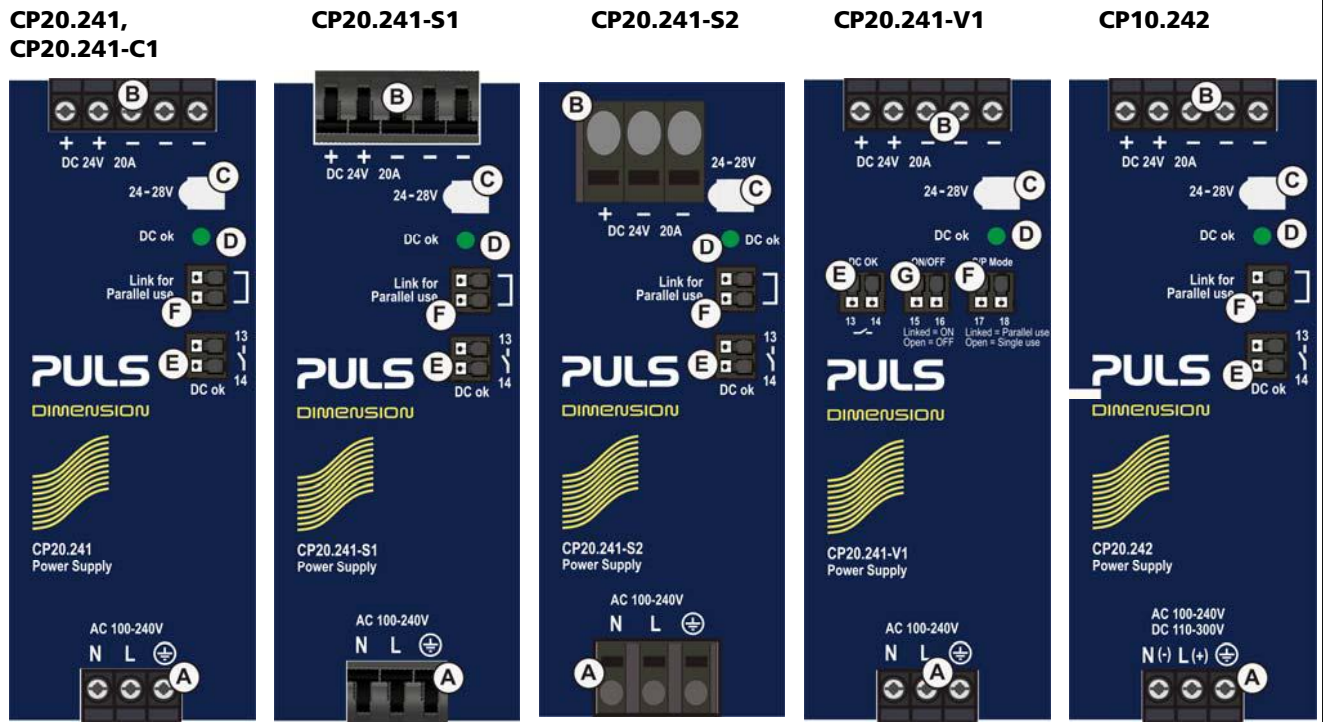

A Input Terminals

- N, L** Line input
- ⊕ PE (Protective Earth) input

B Output Terminals

- CP20.241-S2:** one + pole and two identical - poles
- All other units:** two identical + poles and three identical - poles
- + Positive output
- Negative (return) output

C Output Voltage Potentiometer

D DC-OK LED (green) On, when the output voltage is >90% of the adjusted output voltage

E DC-OK Relay Contact The DC-OK relay contact is synchronized with the DC-OK LED. See chapter 8 for details.

F "Parallel Use" "Single Use" Link

Link the two terminal poles when power supplies are connected in parallel. In order to achieve a sharing of the load current between the individual power supplies, the "parallel use" regulates the output voltage in such a manner that the voltage at no load is approx. 4% higher than at nominal load. See also chapter 24.4.

G Remote ON/OFF Input Pin 15 and 16 must be connected to turn the power supply off. See chapter 9 for details.

16. EMC

The EMC behavior of the device is designed for applications in industrial environment as well as in residential, commercial and light industry environments.

EMC Immunity		According to the generic standards EN 61000-6-1 and EN 61000-6-2.		
Electrostatic discharge	EN 61000-4-2	Contact discharge	8kV	Criterion A
		Air discharge	15kV	Criterion A
Electromagnetic RF field	EN 61000-4-3	80MHz-2.7GHz	20V/m	Criterion A
Fast transients (Burst)	EN 61000-4-4	Input lines	4kV	Criterion A
		Output lines	2kV	Criterion A
		Signal lines (coupling clamp)	2kV	Criterion A
Surge voltage on input	EN 61000-4-5	L → N	2kV	Criterion A
		L → PE, N → PE	4kV	Criterion A
Surge voltage on output	EN 61000-4-5	+ → -	1kV	Criterion A
		+ / - → PE	2kV	Criterion A
Surge voltage on DC-OK	EN 61000-4-5	Signal lines → PE	1kV	Criterion A
Conducted disturbance	EN 61000-4-6	0.15-80MHz	20V	Criterion A
Mains voltage dips	EN 61000-4-11	0% of 100Vac	0Vac, 20ms	Criterion A
		40% of 100Vac	40Vac, 200ms	Criterion C
		70% of 100Vac	70Vac, 500ms	Criterion A
		0% of 200Vac	0Vac, 20ms	Criterion A
		40% of 200Vac	80Vac, 200ms	Criterion A
		70% of 200Vac	140Vac, 500ms	Criterion A
Voltage interruptions	EN 61000-4-11	0% of 200Vac (=0V)	5000ms	Criterion C
Voltage sags	SEMI F47 0706	Dips on the input voltage according to SEMI F47 standard		
		80% of 120Vac (96Vac)	1000ms	Criterion A
		70% of 120Vac (84Vac)	500ms	Criterion A
		50% of 120Vac (60Vac)	200ms	Criterion A
Powerful transients	VDE 0160	Over entire load range	750V, 0.3ms	Criterion A

Criteria:

- A:** Power supply shows normal operation behavior within the defined limits.
- C:** Temporary loss of function is possible. Device may shut-down and restarts by itself. No damage or hazards for the device will occur.

EMC Emission		According to the generic standards EN 61000-6-3 and EN 61000-6-4.	
Conducted emission input lines	EN 55011, EN 55022, FCC Part 15, CISPR 11, CISPR 22	Class B	
Conducted emission output lines	IEC/CISPR 16-1-2, IEC/CISPR 16-2-1	T.B.D. for information only, not mandatory for EN 61000-6-3	
Radiated emission	EN 55011, EN 55022	Class B	
Harmonic input current	EN 61000-3-2	Class A equipment: fulfilled Class C equipment: fulfilled in the load range from 8 to 24A	
Voltage fluctuations, flicker	EN 61000-3-3	Fulfilled, tested with constant current loads, non pulsing	

This device complies with FCC Part 15 rules.

Operation is subjected to following two conditions: (1) this device may not cause harmful interference, and (2) this device must accept any interference received, including interference that may cause undesired operation.



CP20.241, CP20.241-C1, CP20.241-S1,
CP20.241-S2, CP20.241-V1, CP20.242

DIMENSION

CP-Series

24V, 20A, 480W, SINGLE PHASE

Switching Frequencies

PFC converter	100kHz	Fixed frequency
Main converter	80kHz to 140kHz	Output load dependent
Auxiliary converter	60kHz	Fixed frequency

17. ENVIRONMENT

Operational temperature	-25°C to +70°C (-13°F to 158°F)	The operational temperature is the ambient or surrounding temperature and is defined as the air temperature 2cm below the device.
Storage temperature	-40°C to +85°C (-40°F to 185°F)	For storage and transportation
Output de-rating	6.4W/°C 12W/°C 30W/1000m or 5°C/1000m 18W/-5kPa or 3°C/-5kPa The de-rating is not hardware controlled. The customer has to take care by himself to stay below the de-rated current limits in order not to overload the unit.	Between +45°C and +60°C (113°F to 140°F) Between +60°C and +70°C (140°F to 158°F) For altitudes >2000m (6560ft), see Fig. 17-2 For atmospheric pressures <80kPa, see Fig. 17-2
Humidity	5 to 95% r.h.	According to IEC 60068-2-30 Do not energize while condensation is present.
Atmospheric pressure	110-47kPa	See Fig. 17-2 for details
Altitude	Up to 6000m (20 000ft)	See Fig. 17-2 for details
Over-voltage category	III II	According to IEC 60664-1 for altitudes up to 2000m According to IEC 60664-1 for altitudes from 2000 to 6000m and atmospheric pressures from 80 to 47kPa
Degree of pollution	2	According to IEC 62477-1, not conductive
Vibration sinusoidal	2-17.8Hz: ±1.6mm; 17.8-500Hz: 2g 2 hours / axis	According to IEC 60068-2-6
Shock	30g 6ms, 20g 11ms 3 bumps / direction, 18 bumps in total Shock and vibration is tested in combination with DIN-Rails according to EN 60715 with a height of 15mm and a thickness of 1.3mm and standard orientation.	According to IEC 60068-2-27
LABS compatibility	As a rule, only non-silicon precipitating materials are used. The unit conforms to the LABS criteria and is suitable for use in paint shops.	
Corrosive gases	Tested according to ISA-71.04-1985, Severity Level G3 and IEC 60068-2-60 Test Ke Method 4 for a service life of minimum 10years in these environments.	
Audible noise	Some audible noise may be emitted from the power supply during no load, overload or short circuit.	

Fig. 17-1 Output current vs. ambient temp.

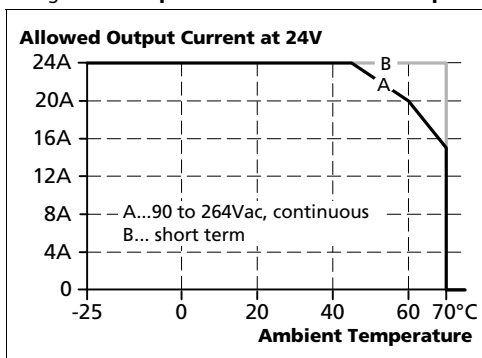
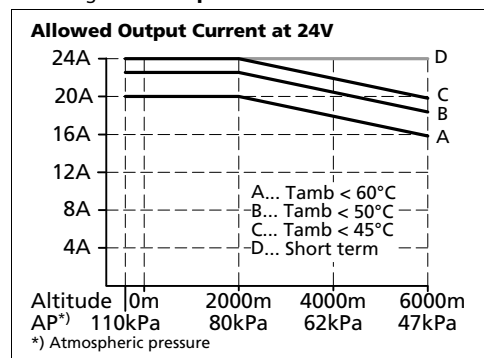

Fig. 17-2 Output current vs. altitude



18. SAFETY AND PROTECTION FEATURES

Isolation resistance	Min.	500MΩ	At delivered condition between input and output, measured with 500Vdc
	Min.	500MΩ	At delivered condition between input and PE, measured with 500Vdc
	Min.	500MΩ	At delivered condition between output and PE, measured with 500Vdc
	Min.	500MΩ	At delivered condition between output and DC-OK contacts, measured with 500Vdc
PE resistance	Max.	0.1Ω	Resistance between PE terminal and the housing in the area of the DIN-rail mounting bracket.
Output over-voltage protection	Typ.	30.5Vdc	In case of an internal defect, a redundant circuit limits the maximum output voltage. The output shuts down and automatically attempts to restart.
	Max.	32Vdc	
Class of protection		I	According to IEC 61140 A PE (Protective Earth) connection is required
Degree of protection		IP 20	According to EN/IEC 60529
Over-temperature protection		Included	Output shut-down with automatic restart. Temperature sensors are installed on critical components inside the unit and turn the unit off in safety critical situations, which can happen e.g. when ambient temperature is too high, ventilation is obstructed or the de-rating requirements are not followed. There is no correlation between the operating temperature and turn-off temperature since this is dependent on input voltage, load and installation methods.
Input transient protection		MOV (Metal Oxide Varistor)	For protection values see chapter 16 (EMC).
Internal input fuse		Included	Not user replaceable slow-blow high-braking capacity fuse
Touch current (leakage current)	Typ.	0.12mA / 0.31mA	At 100Vac, 50Hz, TN-,TT-mains / IT-mains
	Typ.	0.18mA / 0.45mA	At 120Vac, 60Hz, TN-,TT-mains / IT-mains
	Typ.	0.30mA / 0.76mA	At 230Vac, 50Hz, TN-,TT-mains / IT-mains
	Max.	0.16mA / 0.38mA	At 110Vac, 50Hz, TN-,TT-mains / IT-mains
	Max.	0.23mA / 0.55mA	At 132Vac, 60Hz, TN-,TT-mains / IT-mains
	Max.	0.39mA / 0.94mA	At 264Vac, 50Hz, TN-,TT-mains / IT-mains
Penetration protection	Max.	5mm in diameter	E.g. screws, small parts

19. DIELECTRIC STRENGTH

The output voltage is floating and has no ohmic connection to the ground. Type and routine tests are conducted by the manufacturer. Field tests may be conducted in the field using the appropriate test equipment which applies the voltage with a slow ramp (2s up and 2s down). Connect all input-terminals together as well as all output poles before conducting the test. When testing, set the cut-off current settings to the value in the table below.

Fig. 19-1 Dielectric strength

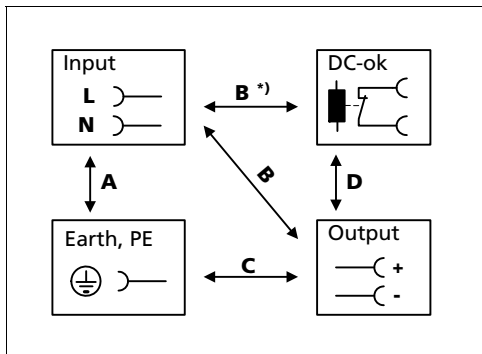









		A	B	C	D
Type test	60s	2500Vac	3000Vac	1000Vac	500Vac
Routine test	5s	2500Vac	2500Vac	500Vac	500Vac
Field test	5s	2000Vac	2000Vac	500Vac	500Vac
Cut-off current setting for field test		> 10mA	> 10mA	> 20mA	> 1mA



We recommend that either the + pole, the - pole or any other part of the output circuit shall be connected to the protective earth system. This helps to avoid situations in which a load starts unexpectedly or can not be switched off when unnoticed earth faults occur.

B*) When testing input to DC-OK ensure that the maximal voltage between DC-OK and the output is not exceeded (column D). We recommend connecting DC-OK pins and the output pins together when performing the test.

20. APPROVALS

EC Declaration of Conformity		The CE mark indicates conformance with the - EMC directive, - Low-voltage directive and the - ATEX directive
IEC 60950-1 2 nd Edition (except for CP20.242)		CB Scheme, Information Technology Equipment
UL 508 (except for CP20.242)		Listed for use as Industrial Control Equipment; U.S.A. (UL 508) and Canada (C22.2 No. 107-1-01); E-File: E198865
UL 60950-1 2 nd Edition (except for CP20.242)		Recognized for use as Information Technology Equipment, Level 5; U.S.A. (UL 60950-1) and Canada (C22.2 No. 60950-1); E-File: E137006 Applicable for altitudes up to 2000m.
ANSI / ISA 12.12.01 Class I Div 2 pending		Hazardous Location Class I Div 2 T4 Groups A,B,C,D systems; U.S.A. (ANSI / ISA 12.12.01) and Canada (C22.2 No. 213)
EN 60079-0, EN 60079-7 ATEX (except for CP20.242)	 II 3G Ex ec nC II T4 Gc	Approval for use in hazardous locations Zone 2 Category 3G. Number of ATEX certificate: EPS 17 ATEX 1 089 X
IEC 60079-0, IEC 60079-7 (except for CP20.242)		Suitable for use in Class 1 Zone 2 Groups IIa, IIb and IIc locations. Number of IECEx certificate: EPS 17.0046X
EAC TR Registration (except for CP20.241-V1 and CP20.242)		Registration for the Eurasian Customs Union market (Russia, Kazakhstan, Belarus)

21. OTHER FULFILLED STANDARDS

RoHS Directive		Directive 2011/65/EU of the European Parliament and the Council of June 8 th , 2011 on the restriction of the use of certain hazardous substances in electrical and electronic equipment.
REACH Directive		Directive 1907/2006/EU of the European Parliament and the Council of June 1 st , 2007 regarding the Registration, Evaluation, Authorisation and Restriction of Chemicals (REACH)
IEC/EN 61558-2-16 (Annex BB)	Safety Isolating Transformer	Safety Isolating Transformers corresponding to Part 2-6 of the IEC/EN 61558

22. PHYSICAL DIMENSIONS AND WEIGHT

Width	48mm 1.89"
Height	124mm 4.88"
Depth	127mm 5.0"
	The DIN-rail height must be added to the unit depth to calculate the total required installation depth.

Weight	830g / 1.83lb
DIN-Rail	Use 35mm DIN-rails according to EN 60715 or EN 50022 with a height of 7.5 or 15mm.
Housing material	Body: Aluminium alloy Cover: zinc-plated steel
Installation clearances	See chapter 2

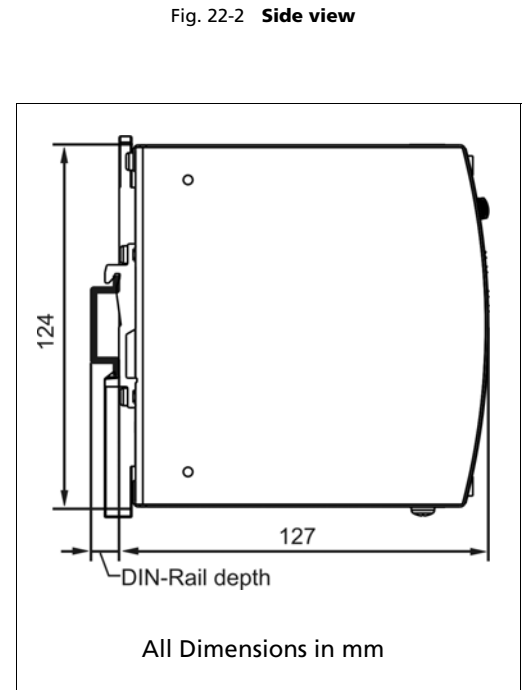
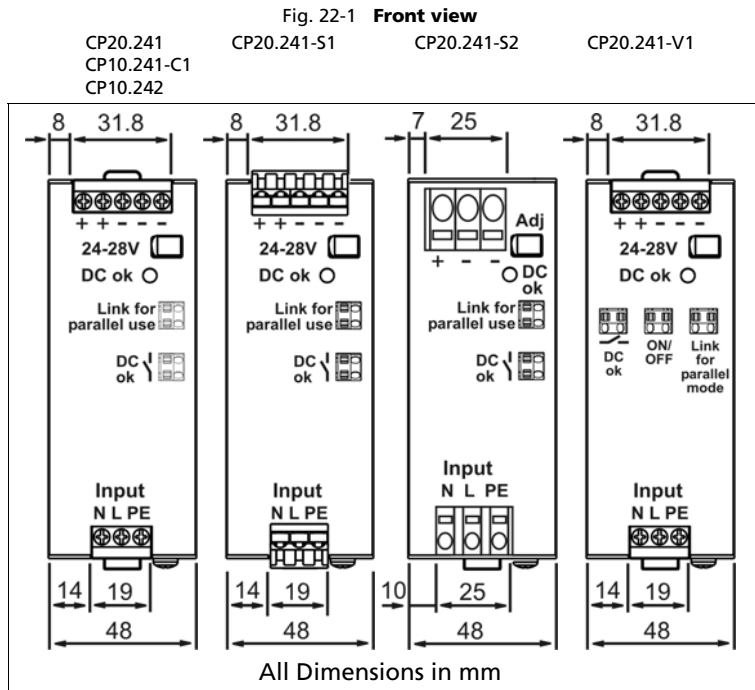

23. ACCESSORIES

23.1. UF20.241 BUFFER MODULE



This buffer unit is a supplementary device for DC 24V power supplies. It delivers power to bridge typical mains failures or extends the hold-up time after turn-off of the AC power. In times when the power supply provides sufficient voltages, the buffer unit stores energy in integrated electrolytic capacitors. In case of mains voltage fault, this energy is released again in a regulated process. One buffer module can deliver 20A additional current.

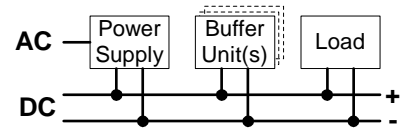

The buffer unit does not require any control wiring. It can be added in parallel to the load circuit at any given point. Buffer units can be added in parallel to increase the output ampacity or the hold-up time.

23.2. YR40.241/242 - REDUNDANCY MODULES



The YR40.241 and YR40.242 redundancy modules are equipped with two input channels (each 20A), which are individually decoupled by utilizing MOSFET technology. The output current can be as high as 40A. Using MOSFETs instead of diodes reduces the heat generation and the voltage drop between input and output. The modules do not require an additional auxiliary voltage and are self-powered even in case of a short circuit across the output.

Due to the low power losses, the units are very slender and only require 36mm width on the DIN-rail.

The YR40.241 can be used in combination with any power supply while the YR40.242 is optimized for use in combination with power supplies featured with the HiccupPLUS overload behavior. The terminal arrangement of the YR40.242 is reversed to the YR40.241. Further information and wiring configurations can be found in chapter 24.5.

23.3. YR40.245 - REDUNDANCY MODULES



The YR40.245 is a 40A single channel redundancy module, which is equipped with a plug connector on the output. The plug connector allows replacing the power supply or the redundancy module while the system is running. The plug connector avoids that the output wires can touch and short the load circuit.

The YR40.245 is very slender and only requires 46mm width on the DIN-rail. It also utilizes MOSFET technology instead of diodes for low heat generation and a minimal voltage drop between input and output. It does not require an additional auxiliary voltage and is self-powered even in case of a short circuit across the output.

Further information and wiring configurations can be found in chapter 24.5.

23.4. ZM5.WALL – WALL/PANEL MOUNT BRACKET



This bracket is used to mount the devices on a wall/panel without utilizing a DIN-Rail. It is suitable for CP20.241, CP20.241-C1, CP20.241-V1, CP20.241-S1 and CP20.241-S2.

The bracket can be mounted without detaching the DIN-rail brackets.

Fig. 23-1 **Isometric view**
(Picture shows the CP20.241)

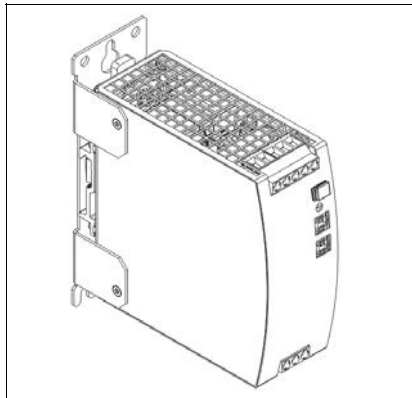

Fig. 23-2 **Isometric view-**
(Picture shows the CP20.241)

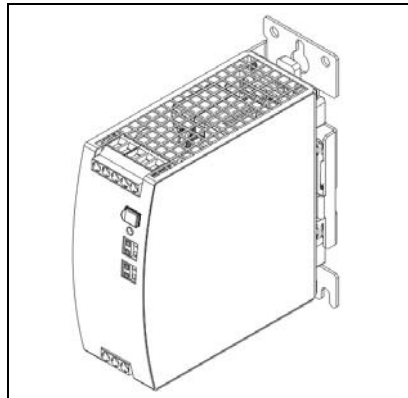

Fig. 23-3 **Isometric view**
(Picture shows the CP20.241)

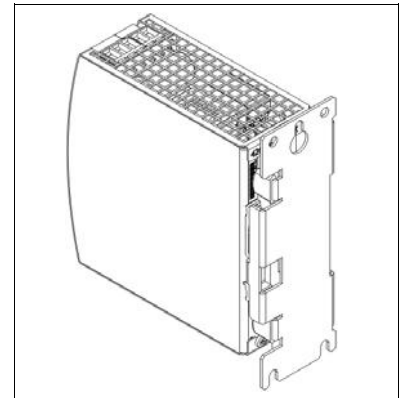

Fig. 23-4 **Wall/panel mounting, front view**
(Picture shows the CP20.241)

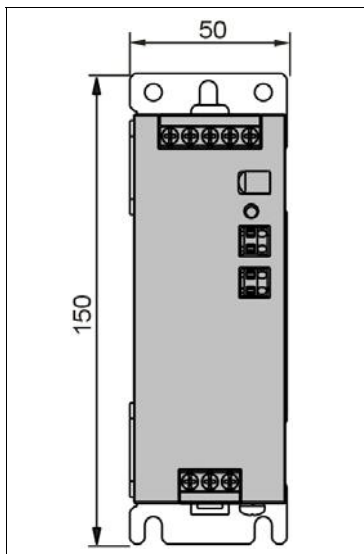

Fig. 23-5 **Hole pattern for wall mounting**

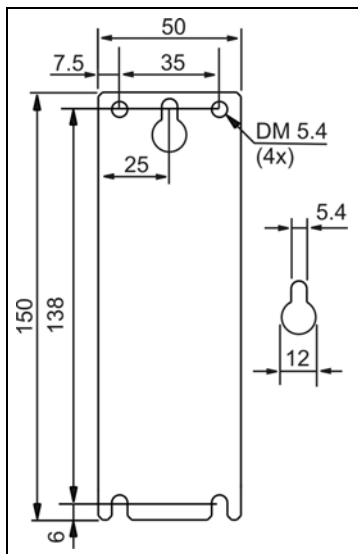
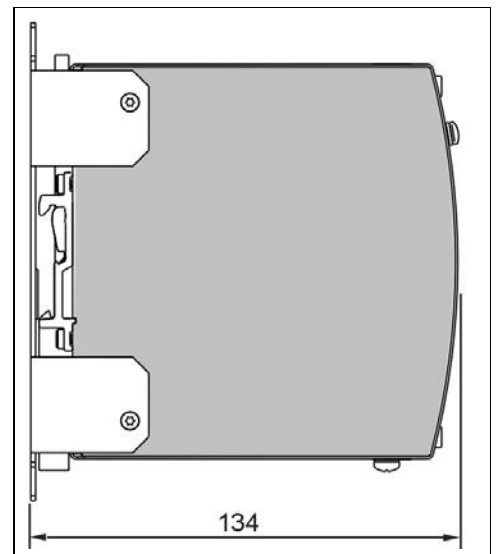

Fig. 23-6 **Wall/panel mounting, side view**
(Picture shows the CP20.241)



24. APPLICATION NOTES

24.1. PEAK CURRENT CAPABILITY

The unit can deliver peak currents (up to several milliseconds) which are higher than the specified short term currents. This helps to start current demanding loads. Solenoids, contactors and pneumatic modules often have a steady state coil and a pick-up coil. The inrush current demand of the pick-up coil is several times higher than the steady-state current and usually exceeds the nominal output current (including the PowerBoost). The same situation applies when starting a capacitive load.

The peak current capability also ensures the safe operation of subsequent circuit breakers of load circuits. The load branches are often individually protected with circuit breakers or fuses. In case of a short or an overload in one branch circuit, the fuse or circuit breaker need a certain amount of over-current to open in a timely manner. This avoids voltage loss in adjacent circuits.

The extra current (peak current) is supplied by the power converter and the built-in large sized output capacitors of the power supply. The capacitors get discharged during such an event, which causes a voltage dip on the output. The following three examples show typical voltage dips for resistive loads:

Fig. 24-1 40A peak current for 50ms, typ. (2x the nominal current)

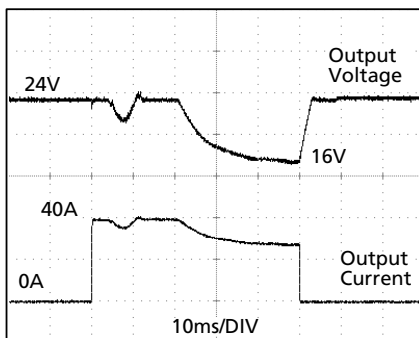

Fig. 24-2 100A peak current for 5ms, typ. (5x the nominal current)

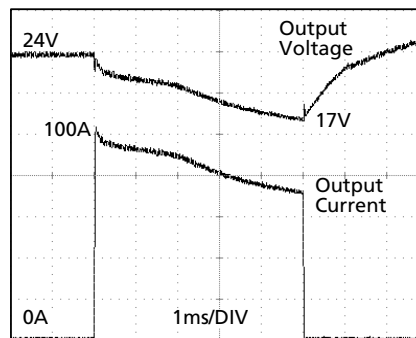
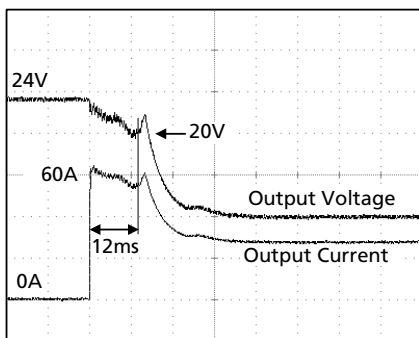

Fig. 24-3 60A peak current for 12ms, typ. (3x the nominal current)



Please note: The DC-OK relay might trigger when the voltage dips more than 10% for longer than 1ms.

Peak current voltage dips	Typ.	from 24V to 16V	At 40A for 50ms, resistive load
	Typ.	from 24V to 21V	At 100A for 2ms, resistive load
	Typ.	from 24V to 17V	At 100A for 5ms, resistive load

24.2. OUTPUT CIRCUIT BREAKERS

Standard miniature circuit breakers (MCB's or UL 1077 circuit breakers) are commonly used for AC-supply systems and may also be used on 24V branches.

MCB's are designed to protect wires and circuits. If the ampere value and the characteristics of the MCB are adapted to the wire size that is used, the wiring is considered as thermally safe regardless of whether the MCB opens or not.

To avoid voltage dips and under-voltage situations in adjacent 24V branches which are supplied by the same source, a fast (magnetic) tripping of the MCB is desired. A quick shutdown within 10ms is necessary corresponding roughly to the ride-through time of PLC's. This requires power supplies with high current reserves and large output capacitors. Furthermore, the impedance of the faulty branch must be sufficiently small in order for the current to actually flow. The best current reserve in the power supply does not help if Ohm's law does not permit current flow. The following table has typical test results showing which B- and C-Characteristic MCBs magnetically trip depending on the wire cross section and wire length.

Fig. 24-4 Test circuit

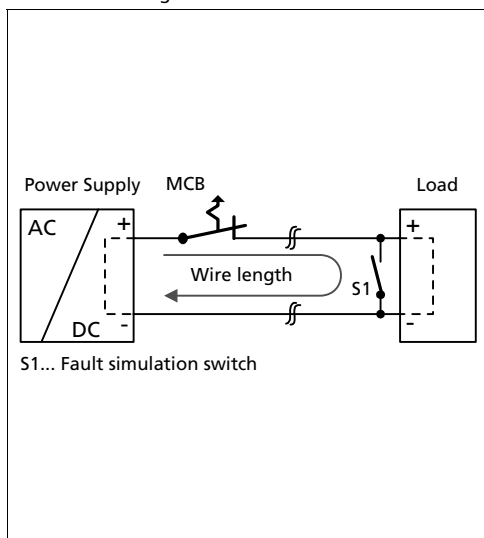

Maximal wire length^{*)} for a fast (magnetic) tripping:

	0.75mm²	1.0mm²	1.5mm²	2.5mm²
C-2A	31 m	37 m	63 m	98 m
C-3A	28 m	34 m	51 m	78 m
C-4A	18 m	25 m	38 m	58 m
C-6A	9 m	11 m	18 m	26 m
C-8A	6 m	7 m	12 m	14 m
C-10A	4 m	6 m	11 m	13 m
C-13A	2 m	2 m	4 m	7 m
<hr/>				
B-6A	23 m	28 m	46 m	66 m
B-10A	11 m	14 m	19 m	32 m
B-13A	7 m	11 m	16 m	29 m
B-16A	5 m	6 m	8 m	15 m
B-20A	1 m	1 m	2 m	4 m
B-25A				1 m

*) Don't forget to consider twice the distance to the load (or cable length) when calculating the total wire length (+ and - wire).

24.3. SERIES OPERATION

Power supplies of the same type can be connected in series for higher output voltages. It is possible to connect as many units in series as needed, providing the sum of the output voltage does not exceed 150Vdc. Voltages with a potential above 60Vdc are not SELV any more and can be dangerous. Such voltages must be installed with a protection against touching.

Avoid return voltage (e.g. from a decelerating motor or battery) which is applied to the output terminals.

Keep an installation clearance of 15mm (left / right) between two power supplies and avoid installing the power supplies on top of each other. Do not use power supplies in series in mounting orientations other than the standard mounting orientation (input terminals on bottom of the unit).

Pay attention that leakage current, EMI, inrush current, harmonics will increase when using multiple power supplies.

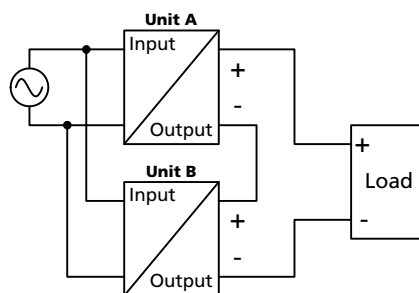

24.4. PARALLEL USE TO INCREASE OUTPUT POWER

Power supplies can be paralleled to increase the output power. The output voltage of all power supplies shall be adjusted to the same value ($\pm 100\text{mV}$) in "Single use" mode with the same load conditions on all units, or the units can be left with the factory settings. After the adjustments, set the unit to "Parallel use" mode, in order to achieve load sharing. The "Parallel use" mode regulates the output voltage in such a manner that the voltage at no load is approx. 4% higher than at nominal load. See also chapter 6.

If more than three units are connected in parallel, a fuse or circuit breaker with a rating of 30A or 32A is required on each output. Alternatively, a diode or redundancy module can also be utilized.

Energize all units at the same time to avoid the overload Hiccup^{PLUS} mode. It also might be necessary to cycle the input power (turn-off for at least five seconds), if the output was in Hiccup^{PLUS} mode due to overload or short circuits and the required output current is higher than the current of one unit.

Keep an installation clearance of 15mm (left / right) between two power supplies and avoid installing the power supplies on top of each other. Do not use power supplies in parallel in mounting orientations other than the standard mounting orientation (input terminals on bottom of the unit) or in any other condition where a derating of the output current is required (e.g. altitude, above 60°C, ...).

Pay attention that leakage current, EMI, inrush current, harmonics will increase when using multiple power supplies.

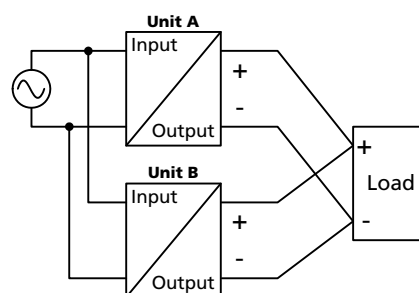

24.5. PARALLEL USE FOR REDUNDANCY

Please note that there are variants with built-in redundancy are available in the CP20 series. Check CP20.241-Rx units.

1+1 Redundancy:

Power supplies can be paralleled for redundancy to gain higher system availability. Redundant systems require a certain amount of extra power to support the load in case one power supply unit fails. The simplest way is to put two power supplies in parallel. This is called a 1+1 redundancy. In case one power supply unit fails, the other one is automatically able to support the load current without any interruption. It is essential to use a redundancy module to decouple power supplies from each other. This prevents that the defective unit becomes a load for the other power supplies and the output voltage cannot be maintained any more.

Recommendations for building redundant power systems:

- Use separate input fuses for each power supply.
- Use separate mains systems for each power supply whenever it is possible.
- Monitor the individual power supply units. Therefore, use the DC-OK signal of the power supply.
- It is desirable to set the output voltages of all units to the same value ($\pm 100\text{mV}$) or leave it at the factory setting.
- Set the power supply into "Parallel use" mode.

Pay attention that leakage current, EMI, inrush current, harmonics will increase when using multiple power supplies.

N+1 Redundancy:

Redundant systems for a higher power demand are usually built in a N+1 method. E.g. four power supplies, each rated for 20A are paralleled to build a 60A redundant system.

Pay attention that leakage current, EMI, inrush current, harmonics will increase when using multiple power supplies.

Keep an installation clearance of 15mm (left / right) between two power supplies and avoid installing the power supplies on top of each other.

Do not use power supplies in parallel in mounting orientations other than the standard mounting orientation or in any other condition, where a de-rating of the output current is required.

Wiring examples for 1+1 and n+1 redundancy:

Fig. 24-5 **1+1 Redundant configuration for 20A load current with a dual redundancy module**

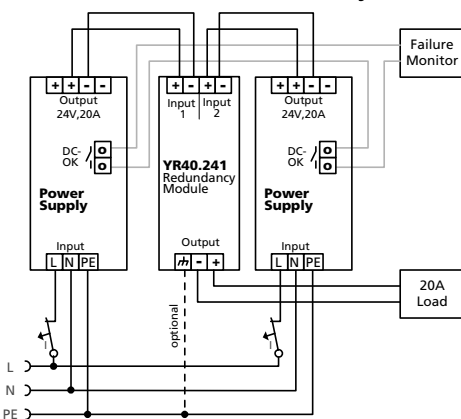

Alternatively, the YR40.242 redundancy module can be used but has the input and output terminals reversed.

Fig. 24-6 **N+1 Redundant configuration for 60A load current with multiple power supplies and redundancy modules**

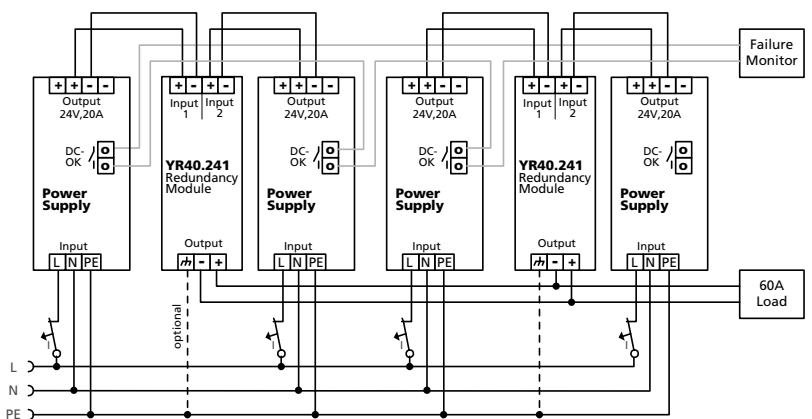

Alternatively, the YR40.242 redundancy module can be used but has the input and output terminals reversed.

24.6. CHARGING OF BATTERIES

The power supply can be used to charge lead-acid or maintenance free batteries. Two 12V SLA or VRLA batteries are needed in series connection.

Instructions for charging batteries:

- a) Set output voltage (measured at no load and at the battery end of the cable) very precisely to the end-of-charge voltage.

End-of-charge voltage	27.8V	27.5V	27.15V	26.8V
Battery temperature	10°C	20°C	30°C	40°C

- b) Use a 30A or 32A circuit breaker (or blocking diode) between the power supply and the battery.
- c) Ensure that the output current of the power supply is below the allowed charging current of the battery.
- d) Ensure that the ambient temperature of the power supply stays below 40°C.
- e) Use only matched batteries when putting 12V types in series.
- f) The return current to the power supply (battery discharge current) is typ. 3.5mA when the power supply is switched off (except in case a blocking diode is utilized).

24.7. OPERATION ON TWO PHASES

The power supply can also be used on two-phases of a three-phase-system. Such a phase-to-phase connection is allowed as long as the supplying voltage is below 240V^{+10%}.

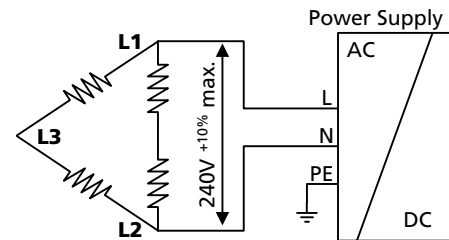

24.8. USE IN A TIGHTLY SEALED ENCLOSURE

When the power supply is installed in a tightly sealed enclosure, the temperature inside the enclosure will be higher than outside. In such situations, the inside temperature defines the ambient temperature for the power supply.

The following measurement results can be used as a reference to estimate the temperature rise inside the enclosure.

The power supply is placed in the middle of the box, no other heat producing items are inside the box

Enclosure:	Rittal Typ IP66 Box PK 9519 100, plastic, 180x180x165mm
Load:	24V, 16A; (=80%) load is placed outside the box
Input:	230Vac
Temperature inside enclosure:	51.7°C (in the middle of the right side of the power supply with a distance of 2cm)
Temperature outside enclosure:	25.9°C
Temperature rise:	25.8K

24.9. MOUNTING ORIENTATIONS

Mounting orientations other than all terminals on the bottom require a reduction in continuous output power or a limitation in the maximum allowed ambient temperature. The amount of reduction influences the lifetime expectancy of the power supply. Therefore, two different derating curves for continuous operation can be found below:

Curve A1

Recommended output current.

Curve A2

Max allowed output current (results in approximately half the lifetime expectancy of A1).

Fig. 24-7
Mounting Orientation A
(Standard orientation)

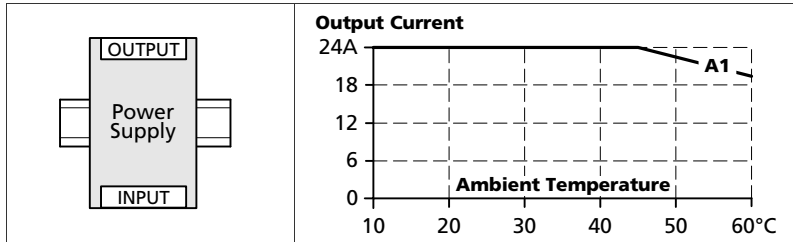

Fig. 24-8
Mounting Orientation B
(Upside down)

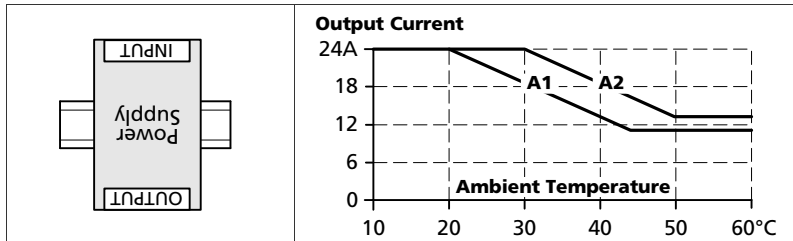

Fig. 24-9
Mounting Orientation C
(Table-top mounting)

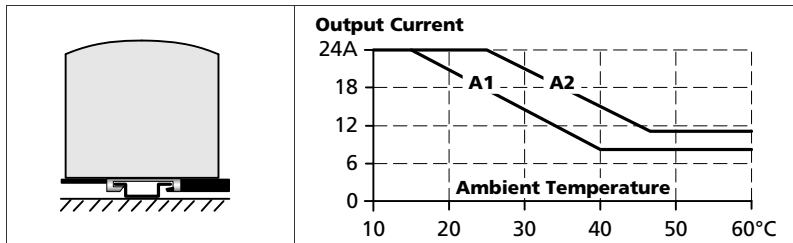

Fig. 24-10
Mounting Orientation D
(Horizontal cw)

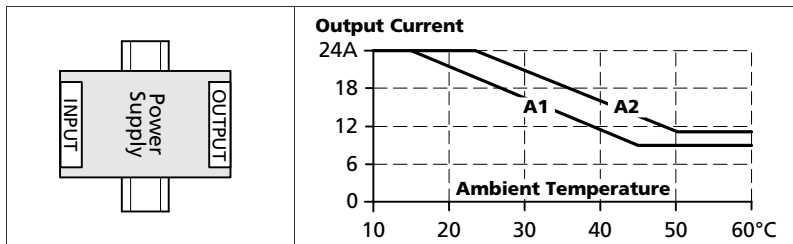

Fig. 24-11
Mounting Orientation E
(Horizontal ccw)

